

* innen bündig zum Verzinken
inside flush for galvanizing

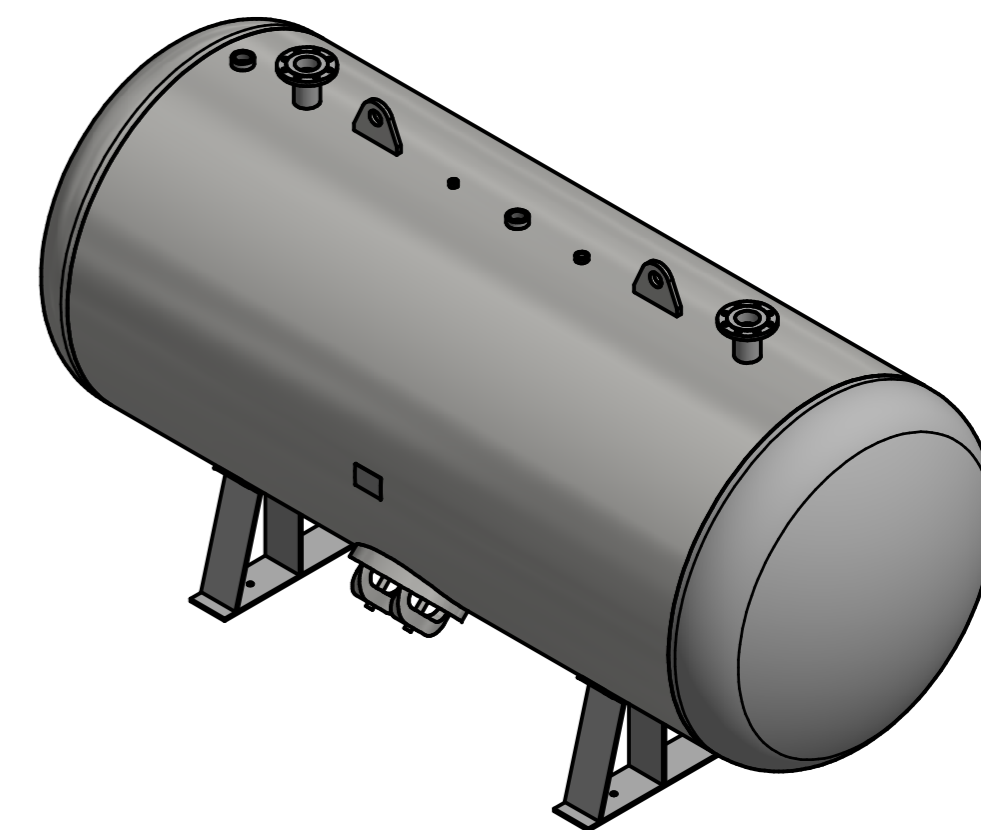

Commission		Pieces:	Scale: 1:20 (1:10)	
Art.Nr.: 105252		Date: 03.07.2023 Name: Blum	Weight: 1400 kg	
		Druckluftbehälter Compressed air receiver 5000 l 16 bar		1/3
		105.534		

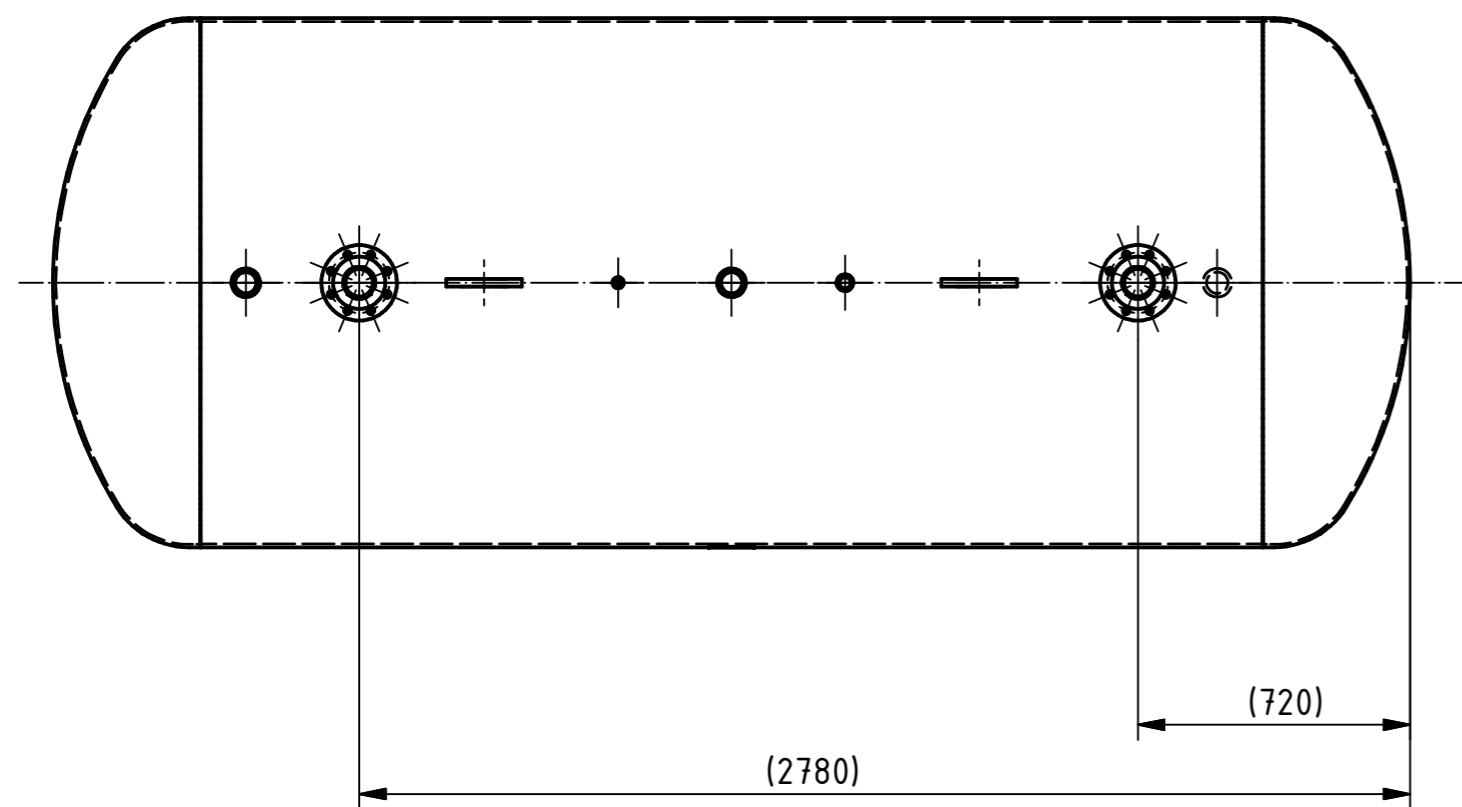
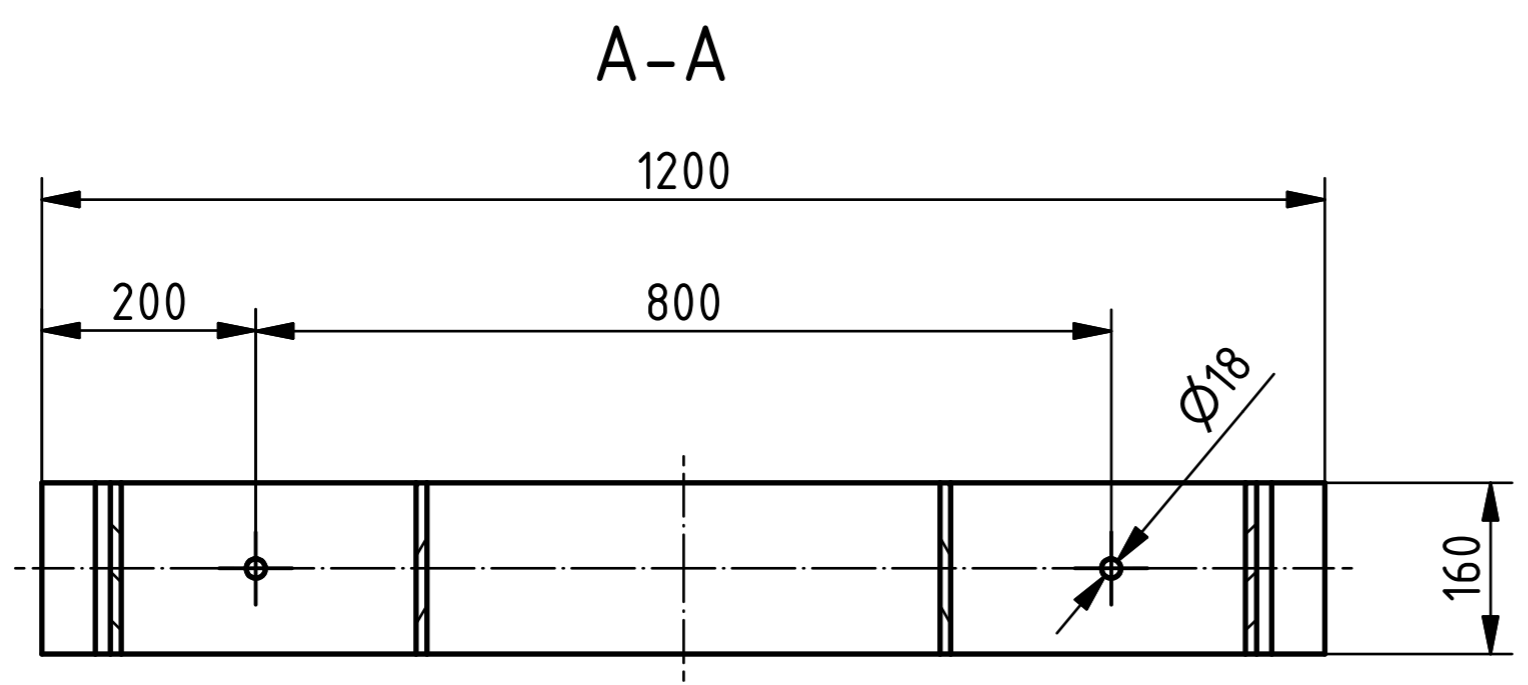
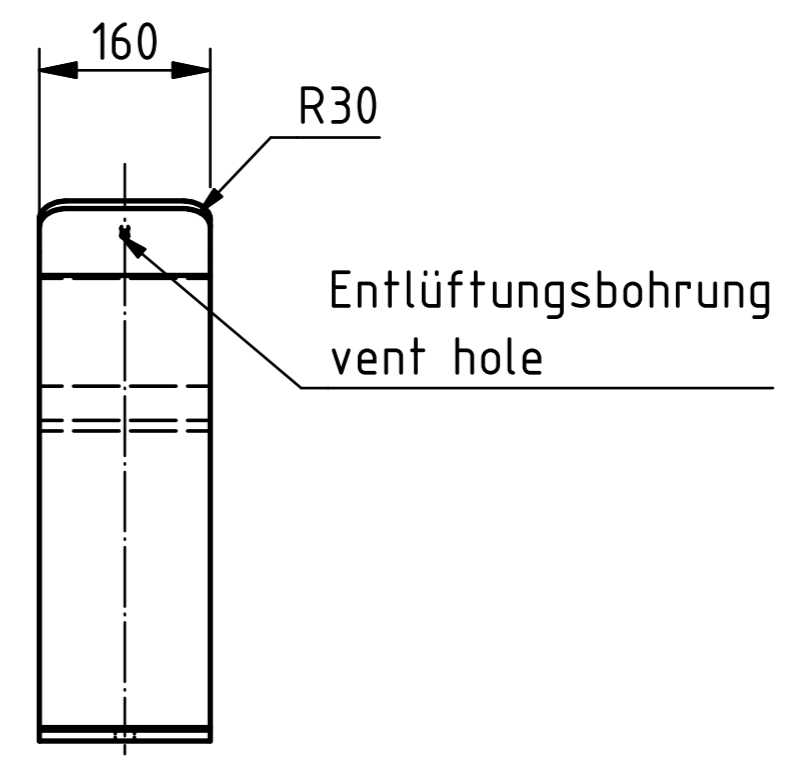
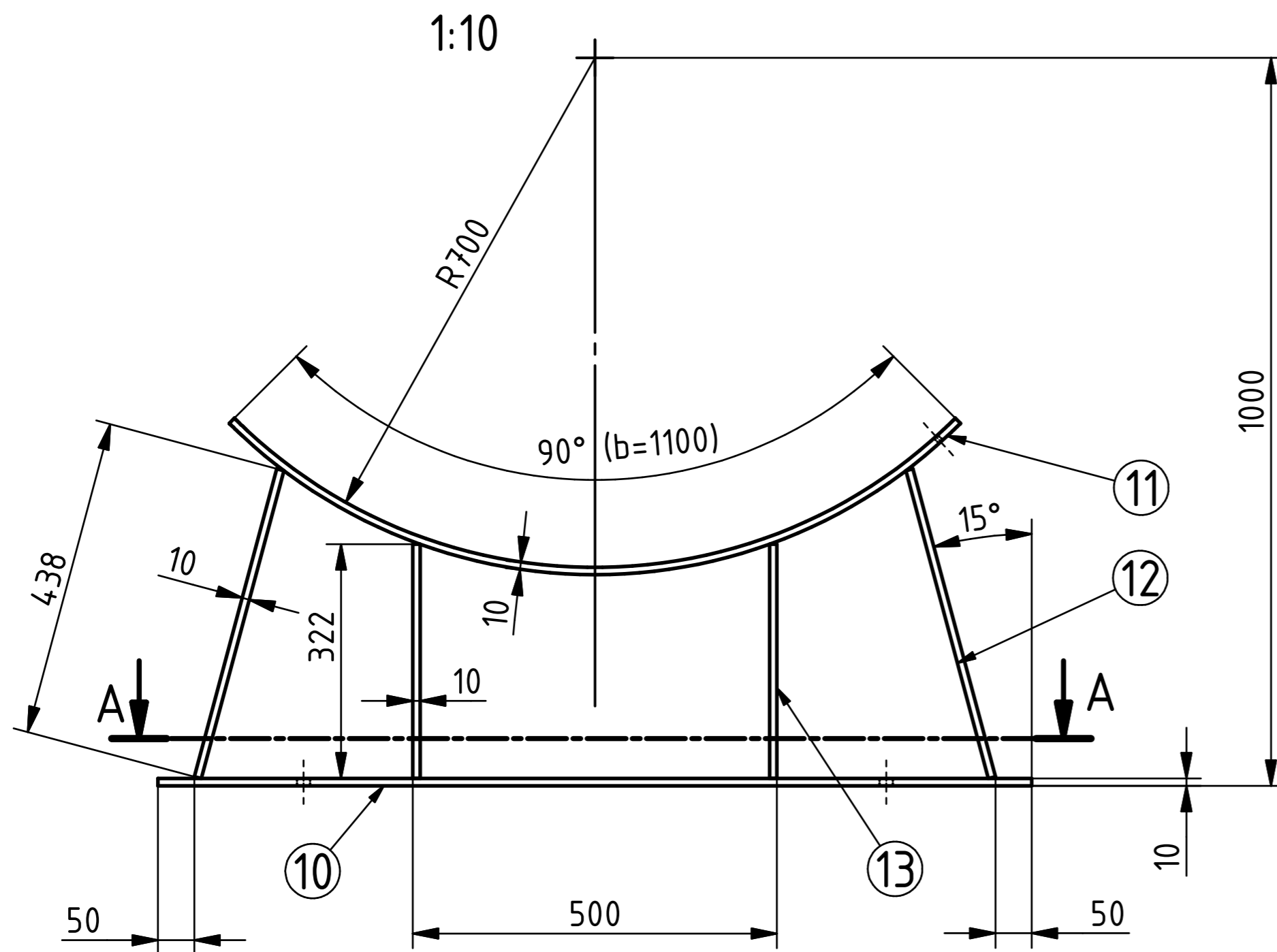

	Pieces:		Scale: 1:20 (1:10)	
			Weight: 1400 kg	
Commission	Date	Name	Druckluftbehälter Compressed air receiver	
	Made by 03.07.2023	Blum		
Checked by				
			5000 l	16 bar
			105.534	2 / 3

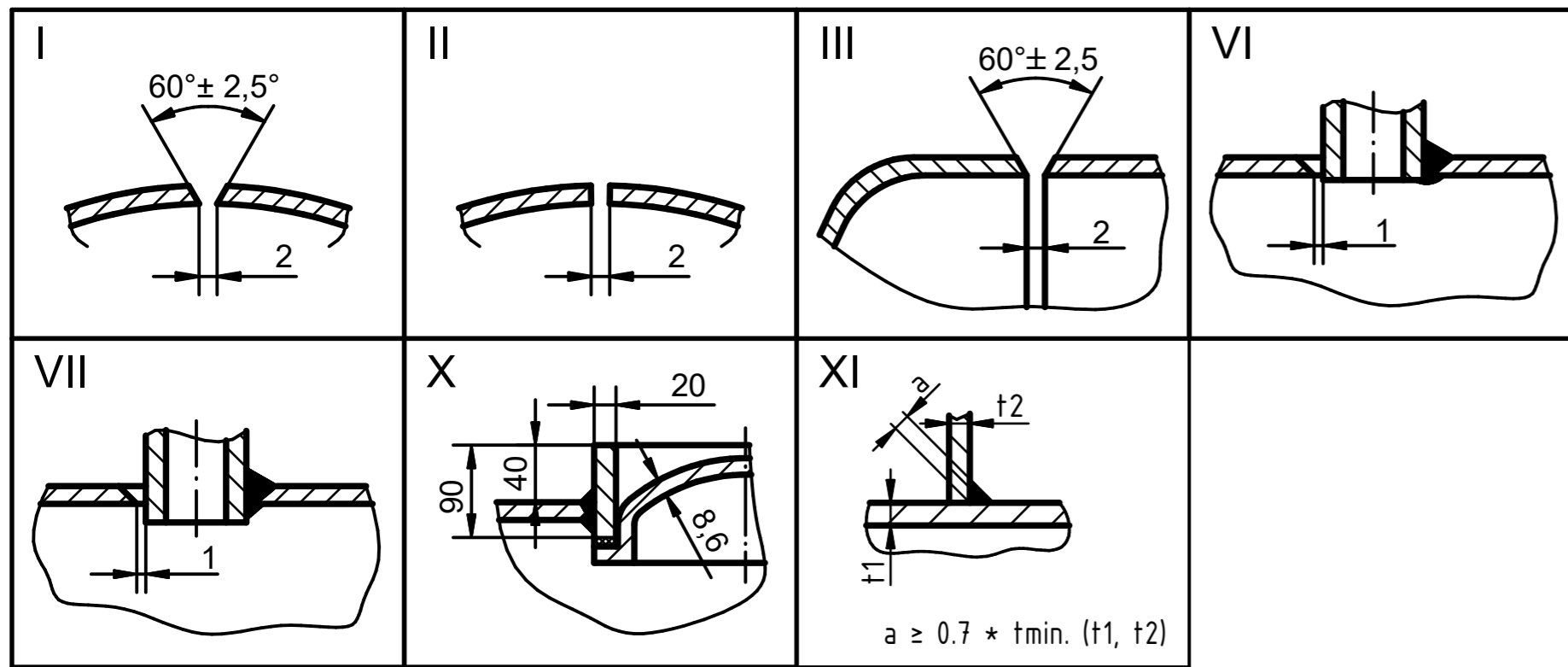

welding acc. to weld map 105.534

operating pressure: 16 bar
 test pressure: 22.88 bar
 operating temperature: -10/50°C
 capacity: 5000 l
 medium: air
 fluid group: 2
 joint factor: 0.85
 allowance for corrosion: 1.0 mm
 design code: AD-2000, 2014/68/EU (PED), category IV, module B (production type)

drawing no. of prod. type: 105....
 inspection by: manufacturer (module D)

Betriebsüberdruck: 16 bar
 Prüfdruck: 22,88 bar
 Betriebstemperatur: -10/50°C
 Inhalt: 5000 l
 Beschickungsgut: Luft
 Fluidgruppe: 2
 Schweißfaktor: 0,85
 Korrosionszuschlag: 1,0 mm
 Berechnungsgrundlage: AD-2000, 2014/68/EU, Kategorie IV, Modul B (Baumuster)

Zeichnungsnr. d. Baumusters: 105....
 Abnahme: Hersteller (Modul D)

Pos.	Pcs.	Benennung / Description	Abmessungen / Dimensions	Norm / Standard	Cert.	Material
1	1	Mantelblech / shell plate	2150 x 4367 x 9,0	EN 10028-2 W1 EN 10204	3.1	P 265 GH
2	2	Kobbogenboden / head DIN 28013	ø1400 x 8,0 min.	EN 10028-2 W1 EN 10204	3.1	P 265 GH
3	1	Mannlochring / man hole ring	90 x 20	EN 10216-2 W4 EN 10204	3.1	P 265 GH
4	1	Mannlochdeckel / man hole cover	sD = 8,6	EN 10028-2 W1 EN 10204	3.1	P 265 GH
5	2	V-Flansch / welding neck flange	Typ 11/Form B1/DN 100/PN 16 EN 1092-1	EN 10222-2 W9 EN 10204	3.1	P 250 GH
6	2	Rohr / pipe	ø88,9 x 8,0 - 110 lg.	EN 10216-2 W4 EN 10204/ EN 10217-2 W4 EN 10204	3.1	P 235 GH
7	4	Muffe / inside threaded connection	G 2" - äø76,1 x 35 lg.	EN 10216-2 W4 EN 10204	3.1	P 235 GH
8	1	Muffe / inside threaded connection	G 1" - äø44,5 x 25 lg.	EN 10216-2 W4 EN 10204	3.1	P 235 GH
9	1	Muffe / inside threaded connection	G 1/2" - äø30 x 25 lg.	EN 10216-2 W4 EN 10204	3.1	P 235 GH
10	2	Fußblech / foot plate	Fl. 160 x 10 - 1200 lg.	EN 10025 W1		S 235 JR
11	2	Verstärkungsblech / doubling plate	Fl. 160 x 10 - 1100 lg.	EN 10025 W1 EN 10204	3.1	S 235 JR
12	4	Seitenblech / plate	Fl. 160 x 10 - 438 lg.	EN 10025 W1		S 235 JR
13	4	Stützblech / plate	Fl. 160 x 10 - 322 lg.	EN 10025 W1		S 235 JR
14	2	Kranöse / lifting eye 02-13	200 x 160 x 20	EN 10025 W1		S 235 JR
15	1	Typenschild / name plate	120 x 85			Folie / foil

Oberflächenbehandlung/surface treatment:
 verzinkt / galvanized

Pieces:		Scale: 1:20 (1:10)	
Commission		Weight: 1400 kg	
Made by	Date	Name	Druckluftbehälter Compressed air receiver 5000 l 16 bar 105.534 3 / 3
Checked by	03.07.2023	Blum	